



thompson
COUPLINGS Limited

TCAE-V



Product Installation Guide

General Information

Thompson Couplings Limited is proud of its products and employs the latest manufacturing techniques to ensure that a premium product is delivered to its customers. Thompson Couplings Limited believes in a high level of quality control to provide only the best products, advice and service.

The fundamental function of a coupling is to transmit power from drive to driven device in a regular action. The TCAE product range is designed to operate at angles, sending torque through the shaft inside the coupling whilst ensuring operation is smooth and efficient.

Owner Responsibility

It is the responsibility of the purchaser to ensure that the product is kept clean, inspected regularly and maintenance is performed as advised

Customer Relations

For any enquiries or assistance please contact:

Thompson Couplings Limited

info@thompsoncouplings.com

Phone: +61 7 3040 8066

Contents

General Information	Page 1
Customer Relations	Page 1
Owners Responsibility	Page 1
Safety Precautions	Page 2
Installation	Page 3

Safety Precautions

To prevent injury to yourself and /or damage to the equipment:

- *Read carefully all owners' manuals, service manuals, and/or other instructions.*
- *Always follow proper procedures and use proper tools and safety equipment.*
- *Be sure to receive proper training, installation and maintenance work should be performed by qualified personnel.*
- *Never work alone while under a vehicle or while repairing or maintaining equipment.*
- *Always use proper components in applications for which they are approved.*
- *Be sure to assemble components properly.*
- *Never use worn-out or damaged components.*
- *Always store and handle coupling safely*
- *Use blocks or adequate racking to prevent coupling moving or rolling away and ensure points are not adversely loaded during storage*



- *Rotating auxiliary coupling is dangerous. You can snag clothes, skin, hair, hands, etc. This can cause serious injury or death.*
- *Do not work on or around the coupling when the engine/motor is running.*
- *Keep hands away from the joint as danger of crushing may occur.*
- *Do not work on or near an exposed coupling when engine/motor is running.*
- *Exposed rotating coupling must be guarded.*



WARNING: THIS SYMBOL WARNS OF POSSIBLE PERSONAL INJURY



WARNING: ROTATING DEVICE

Installation of TCAE coupling

1. Unpacking & inspection, Lifting & Installation

- Minimum **2 persons** lift for TCAE-V-4 to TCAE-V-14 products (see product weight on page 9).



- Ensure no visual external damage has occurred to the shipping box. If it has please contact the shipper and Thompson Couplings Limited for details.
- Ensure all components have been supplied in the packaging:
 - (x1)TCAE-V Coupling
 - (x2)TCAE Quick Release flange (if supplied by TCL)
 - (x2)TCAE Taper lock bush (if supplied by TCL)
 - (x12)TCAE Coupling to flange fasteners (if supplied by TCL)
- Models TCAE-V-00 to TCAE-V-5

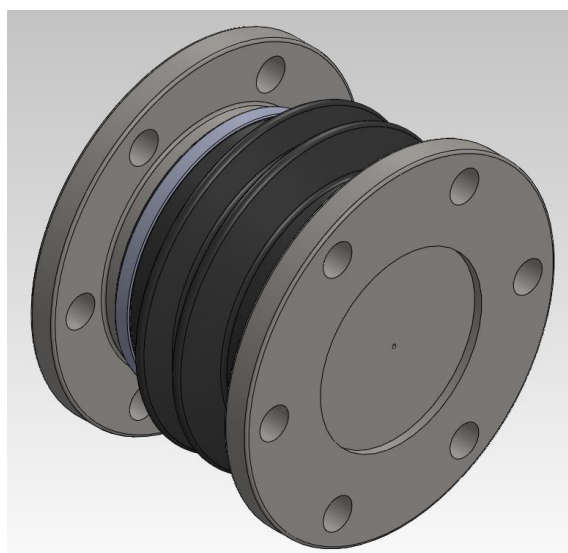

- Models TCAE-V-6 to TCAE-V-14

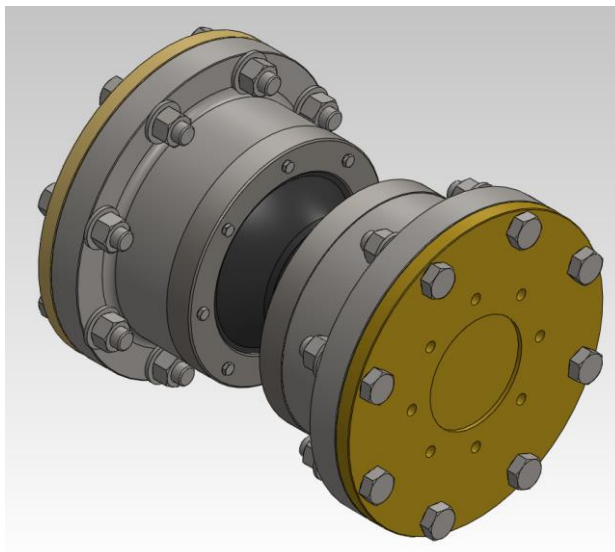

2. Start-up inspection

- If necessary, move the drive / driven device to the correct “end-to-end” shaft distance, in order to fit the TCAE coupling in between.
- Slide the TCAE Taper lock bush inside the TCAE Quick Release Flange. Do not completely tighten the screws from the Taper Lock Bush against the flange. Repeat the operation for the other flange and bush.

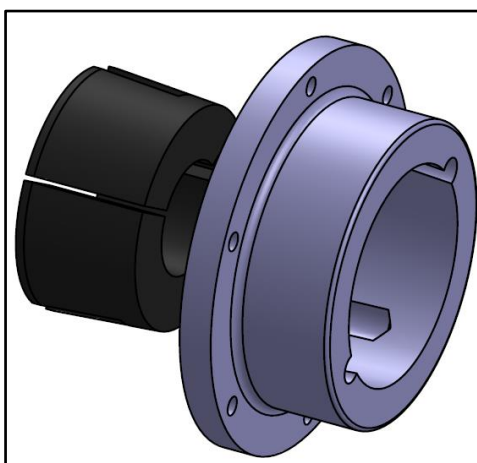

- Slide both TCAE Quick Release flanges on both drive & driven device shafts with appropriate shaft keys. **Locate flange ends flush with the end of the shaft.** Tighten the taper lock bush screws adequately as per torque table on page 6.

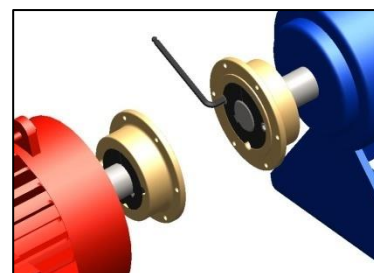
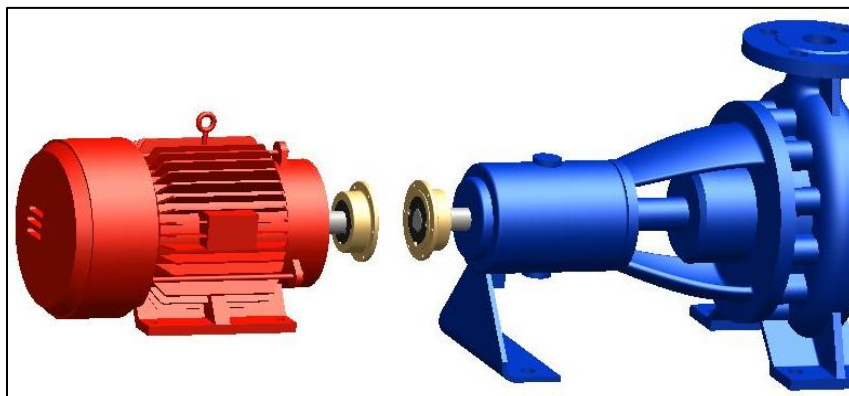

- Before sliding the TCAE coupling between the shafts, make sure that all flanges are clean, dry and free of grease or debris.
- Bring the TCAE coupling and slide it between both Quick Release flanges. Always maintain the TCAE coupling in a horizontal position to avoid damaging the boot or exceeding the maximum bending angle of 5° . Therefore, do not lift the TCAE coupling by one end only but use a sling or other approved lifting device. For larger TCAE couplings, the product may be fitted with an arm lifting support and lifting devices can be used accordingly.
- As a feature of the TCAE product range, the coupling can contract and expand a nominal amount in order to facilitate the installation. While sliding the TCAE coupling horizontally, locate the coupling on both pilot diameters from the Quick Release flange and insert a TCAE coupling to flange fasteners on both sides to temporarily secure the assembly.

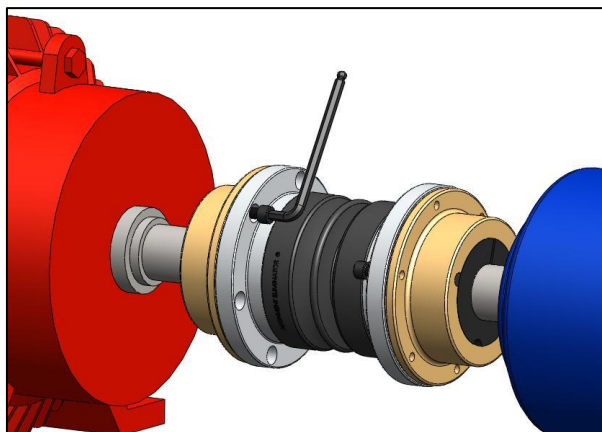

- With the pilot diameters from the TCAE coupling in alignment with the TCAE Quick Release flange and using the remaining TCAE coupling to flange fasteners, secure the coupling on both flanges and tighten in a diametrically opposite sequence to achieve a torque as per torque table below.

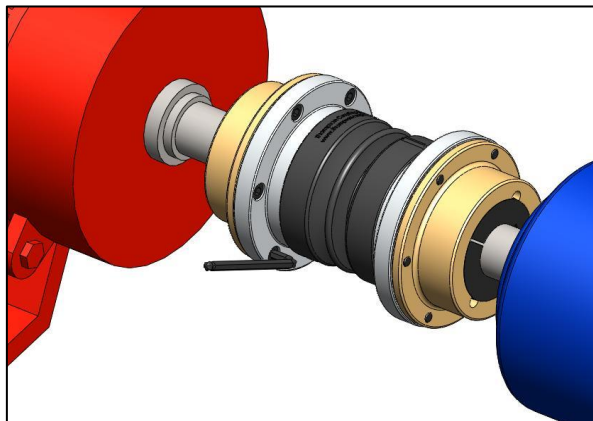

TORQUE TABLE & PRODUCT WEIGHT		
Product	Coupling Weight [kg]	Coupling-Flange Fasteners - Tightening Torque [Nm]
TCAE-V-00	4	15
TCAE-V-0	4	15
TCAE-V-1	6	15
TCAE-V-2	10	15
TCAE-V-3	17	30
TCAE-V-4	25	50
TCAE-V-5	36	50
TCAE-V-6	30	50
TCAE-V-7	39	120
TCAE-V-8	50	120
TCAE-V-9	74	120
TCAE-V-10	103	160
TCAE-V-11	137	240
TCAE-V-12	181	240
TCAE-V-13	226	250
TCAE-V-14	274	250

- Remove all slings and lifting devices if used during the installation.
- Remove tightening allen key.

Start-up Inspection.

- Prior to powering up the new coupling ensure all safety precautions have been observed.
- Ensure all the flange mounting fasteners have been installed and are pre-tensioned to the value specified.
- Make sure the angular or parallel misalignment is not exceeded as per the TCAE product specification sheet. An internal stroke limiting device is incorporated into the coupling and noise (clicking sound) will be heard if misalignment is exceeded.
- Prior to motor start up, ensure the shaft rotates by hand without any jerky sound, noise or friction and all tools have been removed.
- Energise the motor drive (if possible, at jog or low speed) and observe the rotation of the coupling components to ensure all faces are running concentric and true.
- Increase the motor speed to observe any noticeable vibrations or alignment issues. Correct if needed.
- Refit safety cover guards and operate in production mode as required.