



thompson
COUPLINGS Limited

TCAE-S



Product Maintenance Guide

General Information

Thompson Couplings Limited is proud of its products and employs the latest manufacturing techniques to ensure that a premium product is delivered to its customers. Thompson Couplings Limited believes in a high level of quality control to provide only the best products, advice and service.

The fundamental function of a coupling is to transmit power from drive to driven device in a regular action. The TCAE product range is designed to operate at angles, sending torque through the shaft inside the coupling whilst ensuring operation is smooth and efficient.

Owner Responsibility

It is the responsibility of the purchaser to ensure that the product is kept clean, inspected regularly and maintenance is performed as advised.

Customer Relations

For any enquiries or assistance please contact:

Thompson Couplings Limited

info@thompsoncouplings.com

Phone: (+61) 7 3040 8066

Contents

General Information	Page 1
Owners Responsibility	Page 1
Customer Relations	Page 1
Safety Precautions	Page 2
Timetable and Maintenance Intervals	Page 3
Notes	Page 4

Safety Precautions

To prevent injury to yourself and /or damage to the equipment:

- *Read carefully all owners' manuals, service manuals, and/or other instructions.*
- *Always follow proper procedures and use proper tools and safety equipment.*
- *Be sure to receive proper training, installation and maintenance work should be performed by qualified personnel.*
- *Never work alone while under a vehicle or while repairing or maintaining equipment.*
- *Always use proper components in applications for which they are approved.*
- *Be sure to assemble components properly.*
- *Never use worn-out or damaged components.*
- *Always store and handle coupling safely.*
- *Use blocks or adequate racking to prevent coupling moving or rolling away and ensure points are not adversely loaded during storage.*



- *Rotating auxiliary coupling is dangerous. You can snag clothes, skin, hair, hands, etc. This can cause serious injury or death.*
- *Do not work on or around the coupling when the engine/motor is running.*
- *Keep hands away from the joint as danger of crushing may occur.*
- *Do not work on or near an exposed coupling when engine/motor is running.*
- *Exposed rotating coupling must be guarded.*



WARNING: THIS SYMBOL WARNS OF POSSIBLE PERSONAL INJURY



WARNING: ROTATING DEVICE



Timetable and Maintenance Intervals

Item	Period 1 At company scheduled maintenance intervals	Period 2 Every 4,000 hours or 180 days
Check for unusual vibration and noise levels during operation of the coupling. (refer note 2, page 4)	<input checked="" type="checkbox"/>	<input checked="" type="checkbox"/>
Visually inspect coupling for damage. (refer note 1, page 4)	<input checked="" type="checkbox"/>	
Visually inspect seal for damage. (refer note 1, page 4)	<input checked="" type="checkbox"/>	
Ensure that all fasteners are tensioned to values shown in the Torque Table. (refer note 4, page 4)		<input checked="" type="checkbox"/>
In critical applications periodically record the surface temperature of the coupling housing whilst running the coupling to detect abnormal rises in temperature using a non-contact laser thermometer or similar. (refer Note 5, page 5)	<input checked="" type="checkbox"/>	

Notes

1. **Visual inspection procedure:**
 - a. Check for smooth operation with minimal vibration.
 - b. Inspect for build-up of contamination on all rotating parts.
 - c. Inspect for corrosion on all parts and replace as necessary.
2. **Audio inspection procedure:**
 - a. Assess for unusual vibration and corresponding noise levels.
 - b. Listen for unusual noises within the coupling.
3. The TCAE-S coupling is supplied with lifetime lubrication and is therefore maintenance free.
4. Check tension of the following fasteners / screws to the recommended torque settings:

Model	Coupling Weight [kg]	Max Keyed Shaft Diameter [mm]	Hex Bolt Size [grade8.8]	Torque Nm (lb.ft)	Inner and Outer Seal Screws	Torque Nm (lb.ft)
TCAE-S-1	6	30 (Key 8x7)	6 x M14	120 (90)	INNER – 6 x M4 SHCS OUTER – 6 x M4 SHCS	3 (2)
TCAE-S-2	11	40 (Key 12x8)	6 x M14	120 (90)	INNER – 6 x M4 SHCS OUTER – 6 x M4 SHCS	3 (2)
TCAE-S-3	19	50 (Key 14x9)	6 x M16	190 (140)	INNER – 6 x M4 SHCS OUTER – 6 x M6 SHCS	3 (2) 6 (4)
TCAE-S-4	25	55 (Key 16x10)	6 x M16	190 (140)	INNER – 6 x M4 SHCS OUTER – 6 x M6 SHCS	3 (2) 6 (4)
TCAE-S-5	35	60 (Key 18x11)	6 x M20	370 (270)	INNER – 6 x M4 SHCS OUTER – 6 x M6 SHCS	3 (2) 6 (4)
TCAE-S-6	35	65 (Key 18x11)	8 x M12	80 (60)	INNER – 6 x M6 SHCS OUTER – 6 x M6 SHCS	10 (7)
TCAE-S-7	40	65 (Key 18x11)	8 x M14	120 (90)	INNER – 6 x M6 SHCS OUTER – 6 x M6 SHCS	10 (7)
TCAE-S-8	60	85 (Key 22x14)	8 x M14	120 (90)	INNER – 8 x M8 SHCS OUTER – 8 x M8 SHCS	20 (14)
TCAE-S-9	80	110 (Key 28x16)	8 x M16	190 (140)	INNER – 8 x M8 SHCS OUTER – 8 x M8 SHCS	20 (14)
TCAE-S-10	113	125 (Key 32x18)	8 x M18	270 (200)	INNER – 8 x M10 SHCS OUTER – 8 x M10 SHCS	30 (21)
TCAE-S-11	120	130 (Key 32x18)	-	-	-	-
TCAE-S-12	173	150 (Key 26x20)	-	-	-	-
TCAE-S-13	215	170 (Key 40x22)	-	-	-	-
TCAE-S-14	285	200 (Key 46x25)	-	-	-	-

5. It is recommended that a routine check be made of the coupling outer surface temperature using a non-contact thermometer (or similar) to detect any abnormal changes in temperature. The surface temperature is a function of conditions such as: ambient temperature, actual running power and speed, operating angle, duty cycle of the driven device and others. As such it is recommended that the coupling temperature be regularly recorded (usually as part of the plant condition monitoring routines). In normal operating environments (ambient up to 35 deg C) a threshold set point temperature of 60 deg C (140 deg F) should be the first warning signal to increase the frequency of subsequent temperature monitoring times. If the temperature is observed to increase significantly in subsequent inspection periods, or if it starts to exceed a temperature of 85 deg C (185 deg F) or more it should be **stopped** and **replaced (see below Graph for reference)**.

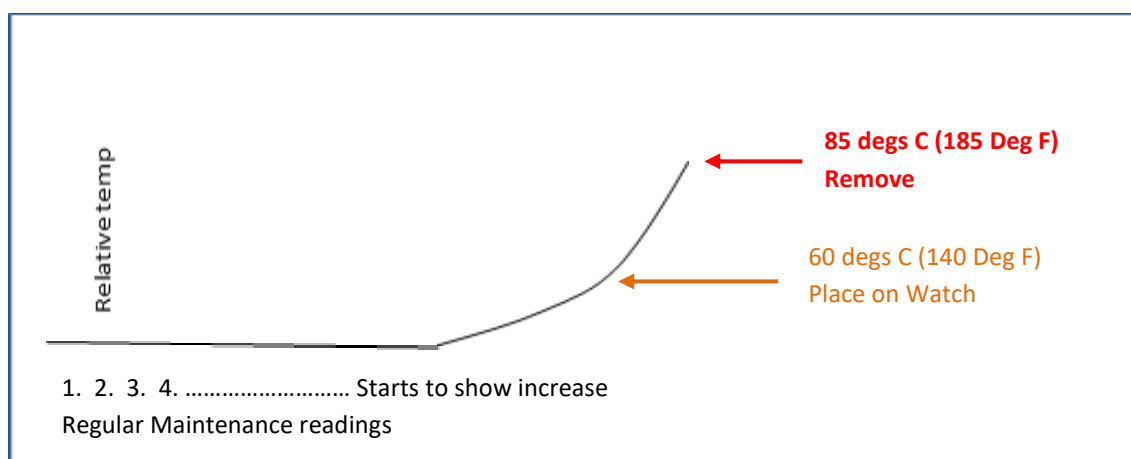

6. Replacement method for coupling or rubber seal: send coupling to TCL or authorised service agent for replacement.
7. At the maximum compound angle for both ends of the TCAE coupling of 10° with a maximum speed as listed below:

Model TCAE-S-1, S-2, S-3, S-4	----- 3,000 rpm (maximum)
Model TCAE-S-5	----- 2,500 rpm (maximum)
Model TCAE-S-6, S-7, S-8	----- 2,200 rpm (maximum)
Model TCAE-S-9	----- 2,000 rpm (maximum)
Model TCAE-S-10	----- 1,500 rpm (maximum)
Model TCAE-S-11	----- 1,400 rpm (maximum)

Model TCAE-S-12 ----- 1,200 rpm (maximum)

Model TCAE-S-13 ----- 1,000 rpm (maximum)

Model TCAE-S-14 ----- 800 rpm (maximum)

8. DBSE (Distance between shaft ends) – During installation, ensure that the critical distance between the shaft ends, are set within the range of the specified dimensions. These dimensions are provided in the table below.

	TCAE-S-1 to TCAE-S-14
Recommended DBSE [mm] (range)	20 (10 to 30)

Models TCAE-S-1 to TCAE-S-7

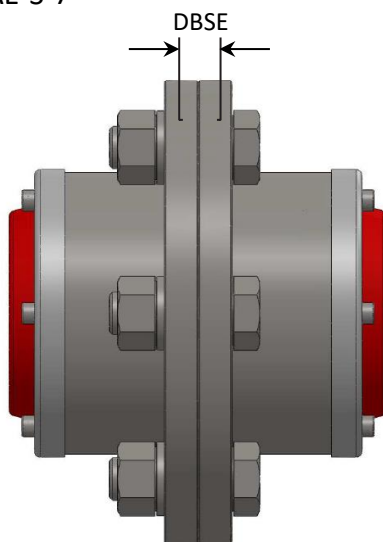

Models TCAE-S-8 to TCAE-S-14

